

Active Low-Pass Filter Design

Jim Karki

AAP Precision Analog

ABSTRACT

This report focuses on active low-pass filter design using operational amplifiers. Low-pass filters are commonly used to implement antialias filters in data-acquisition systems. Design of second-order filters is the main topic of consideration.

Filter tables are developed to simplify circuit design based on the idea of cascading lower-order stages to realize higher-order filters. The tables contain scaling factors for the corner frequency and the required Q of each of the stages for the particular filter being designed. This enables the designer to go straight to the calculations of the circuit-component values required.

To illustrate an actual circuit implementation, six circuits, separated into three types of filters (Bessel, Butterworth, and Chebyshev) and two filter configurations (Sallen-Key and MFB), are built using a TLV2772 operational amplifier. Lab test data presented shows their performance. Limiting factors in the high-frequency performance of the filters are also examined.

Contents

1	Introduction	2
2	Filter Characteristics	3
3	Second-Order Low-Pass Filter – Standard Form	3
4	Math Review	4
5	Examples	4
	5.1 Second-Order Low-Pass Butterworth Filter	5
	5.2 Second-Order Low-Pass Bessel Filter	5
	5.3 Second-Order Low-Pass Chebyshev Filter With 3-dB Ripple	5
6	Low-Pass Sallen-Key Architecture	6
7	Low-Pass Multiple-Feedback (MFB) Architecture	7
8	Cascading Filter Stages	8
9	Filter Tables	8
10	Example Circuit Test Results	11
11	Nonideal Circuit Operation	14
	11.1 Nonideal Circuit Operation – Sallen-Key	14
	11.2 Nonideal Circuit Operation – MFB	16
12	Comments About Component Selection	17
13	Conclusion	17
Appendix A Filter-Design Specifications		19

Appendix B Higher-Order Filters 21
List of Figures

1	Low-Pass Sallen-Key Architecture	6
2	Low-Pass MFB Architecture	7
3	Building Even-Order Filters by Cascading Second-Order Stages	8
4	Building Odd-Order Filters by Cascading Second-Order Stages and Adding a Single Real Pole ...	8
5	Sallen-Key Circuit and Component Values – $f_c = 1$ kHz	11
6	MFB Circuit and Component Values – $f_c = 1$ kHz	11
7	Second-Order Butterworth Filter Frequency Response	12
8	Second-Order Bessel Filter Frequency Response	12
9	Second-Order 3-dB Chebyshev Filter Frequency Response	13
10	Second-Order Butterworth, Bessel, and 3-dB Chebyshev Filter Frequency Response	13
11	Transient Response of the Three Filters	14
12	Second-Order Low-Pass Sallen-Key High-Frequency Model	14
13	Sallen-Key Butterworth Filter With RC Added in Series With the Output	15
14	Second-Order Low-Pass MFB High-Frequency Model	16
15	MFB Butterworth Filter With RC Added in Series With the Output	16
B–1	Fifth-Order Low-Pass Filter Topology Cascading Two Sallen-Key Stages and an RC	22
B–2	Sixth-Order Low-Pass Filter Topology Cascading Three MFB Stages	23

List of Tables

1	Butterworth Filter Table	9
2	Bessel Filter Table	9
3	1-dB Chebyshev Filter Table	10
4	3-dB Chebyshev Filter Table	10
5	Summary of Filter Type Trade-Offs	18
6	Summary of Architecture Trade-Offs	18

1 Introduction

There are many books that provide information on popular filter types like the Butterworth, Bessel, and Chebyshev filters, just to name a few. This paper will examine how to implement these three types of filters.

We will examine the mathematics used to transform standard filter-table data into the transfer functions required to build filter circuits. Using the same method, filter tables are developed that enable the designer to go straight to the calculation of the required circuit-component values. Actual filter implementation is shown for two circuit topologies: the Sallen-Key and the Multiple Feedback (MFB). The Sallen-Key circuit is sometimes referred to as a voltage-controlled voltage source, or VCVS, from a popular type of analysis used.

It is common practice to refer to a circuit as a Butterworth filter or a Bessel filter because its transfer function has the same coefficients as the Butterworth or the Bessel polynomial. It is also common practice to refer to the MFB or Sallen-Key circuits as filters. The difference is that the Butterworth filter defines a transfer function that can be realized by many different circuit topologies (both active and passive), while the MFB or Sallen-Key circuit defines an architecture or a circuit topology that can be used to realize various second-order transfer functions.

The choice of circuit topology depends on performance requirements. The MFB is generally preferred because it has better sensitivity to component variations and better high-frequency behavior. The unity-gain Sallen-Key inherently has the best gain accuracy because its gain is not dependent on component values.

2 Filter Characteristics

If an ideal low-pass filter existed, it would completely eliminate signals above the cutoff frequency, and perfectly pass signals below the cutoff frequency. In real filters, various trade-offs are made to get optimum performance for a given application.

Butterworth filters are termed maximally-flat-magnitude-response filters, optimized for gain flatness in the pass-band. the attenuation is -3 dB at the cutoff frequency. Above the cutoff frequency the attenuation is -20 dB/decade/order. The transient response of a Butterworth filter to a pulse input shows moderate overshoot and ringing.

Bessel filters are optimized for maximally-flat time delay (or constant-group delay). This means that they have linear phase response and excellent transient response to a pulse input. This comes at the expense of flatness in the pass-band and rate of rolloff. The cutoff frequency is defined as the -3 -dB point.

Chebyshev filters are designed to have ripple in the pass-band, but steeper rolloff after the cutoff frequency. Cutoff frequency is defined as the frequency at which the response falls below the ripple band. For a given filter order, a steeper cutoff can be achieved by allowing more pass-band ripple. The transient response of a Chebyshev filter to a pulse input shows more overshoot and ringing than a Butterworth filter.

3 Second-Order Low-Pass Filter – Standard Form

The transfer function H_{LP} of a second-order low-pass filter can be express as a function of frequency (f) as shown in Equation 1. We shall use this as our standard form.

$$H_{LP}(f) = - \frac{K}{\left(\frac{f}{FSF \times fc}\right)^2 + \frac{1}{Q} \frac{jf}{FSF \times fc} + 1}$$

Equation 1. Second-Order Low-Pass Filter – Standard Form

In this equation, f is the frequency variable, fc is the cutoff frequency, FSF is the frequency scaling factor, and Q is the quality factor. Equation 1 has three regions of operation: below cutoff, in the area of cutoff, and above cutoff. For each area Equation 1 reduces to:

- $f \ll fc \Rightarrow H_{LP}(f) \approx K$ – the circuit passes signals multiplied by the gain factor K .
- $\frac{f}{fc} = FSF \Rightarrow H_{LP}(f) = -jKQ$ – signals are phase-shifted 90° and modified by the Q factor.
- $f \gg fc \Rightarrow H_{LP}(f) \approx -K \left(\frac{FSF \times fc}{f}\right)^2$ – signals are phase-shifted 180° and attenuated by the square of the frequency ratio.

With attenuation at frequencies above fc increasing by a power of 2, the last formula describes a second-order low-pass filter.

The frequency scaling factor (FSF) is used to scale the cutoff frequency of the filter so that it follows the definitions given before.

4 Math Review

A second-order polynomial using the variable s can be given in two equivalent forms: the coefficient form: $s^2 + a_1s + a_0$, or the factored form; $(s + z_1)(s + z_2)$ – that is:

$P(s) = s^2 + a_1s + a_0 = (s + z_1)(s + z_2)$. Where $-z_1$ and $-z_2$ are the locations in the s plane where the polynomial is zero.

The three filters being discussed here are all pole filters, meaning that their transfer functions contain all poles. The polynomial, which characterizes the filter's response, is used as the denominator of the filter's transfer function. The polynomial's zeroes are thus the filter's poles.

All even-order Butterworth, Bessel, or Chebyshev polynomials contain complex-zero pairs. This means that $z_1 = \text{Re} + \text{Im}$ and $z_2 = \text{Re} - \text{Im}$, where Re is the real part and Im is the imaginary part. A typical mathematical notation is to use z_1 to indicate the conjugate zero with the positive imaginary part and z_1^* to indicate the conjugate zero with the negative imaginary part. Odd-order filters have a real pole in addition to the complex-conjugate pairs.

Some filter books provide tables of the zeros of the polynomial which describes the filter, others provide the coefficients, and some provide both. Since the zeroes of the polynomial are the poles of the filter, some books use the term poles. Zeroes (or poles) are used with the factored form of the polynomial, and coefficients go with the coefficient form. No matter how the information is given, conversion between the two is a routine mathematical operation.

Expressing the transfer function of a filter in factored form makes it easy to quickly see the location of the poles. On the other hand, a second-order polynomial in coefficient form makes it easier to correlate the transfer function with circuit components. We will see this later when examining the filter-circuit topologies. Therefore, an engineer will typically want to use the factored form, but needs to scale and normalize the polynomial first.

Looking at the coefficient form of the second-order equation, it is seen that when $s \ll a_0$, the equation is dominated by a_0 ; when $s \gg a_0$, s dominates. You might think of a_0 as being the break point where the equation transitions between dominant terms. To normalize and scale to other values, we divide each term by a_0 and divide the s terms by ωc . The result is:

$$P(s) = \left(\frac{s}{\sqrt{a_0} \times \omega c} \right)^2 + \frac{a_1 s}{a_0 \times \omega c} + 1.$$
 This scales and normalizes the polynomial so that the break point is at $s = \sqrt{a_0} \times \omega c$.

By making the substitutions $s = j2\pi f$, $\omega c = 2\pi f c$, $a_1 = \frac{1}{Q}$, and $\sqrt{a_0} = \text{FSF}$, the equation becomes:

$$P(f) = -\left(\frac{f}{\text{FSF} \times f_c} \right)^2 + \frac{1}{Q} \frac{jf}{\text{FSF} \times f_c} + 1,$$
 which is the denominator of Equation 1– our standard form for low-pass filters.

Throughout the rest of this article, the substitution: $s = j2\pi f$ will be routinely used without explanation.

5 Examples

The following examples illustrate how to take standard filter-table information and process it into our standard form.

5.1 Second-Order Low-Pass Butterworth Filter

The Butterworth polynomial requires the least amount of work because the frequency-scaling factor is always equal to one.

From a filter-table listing for Butterworth, we can find the zeroes of the second-order Butterworth polynomial: $z_1 = -0.707 + j0.707$, $z_1^* = -0.707 - j0.707$, which are used with the factored form of the polynomial. Alternately, we find the coefficients of the polynomial: $a_0 = 1$, $a_1 = 1.414$. It can be easily confirmed that $(s + 0.707 + j0.707)(s + 0.707 - j0.707) = s^2 + 1.414s + 1$.

To correlate with our standard form we use the coefficient form of the polynomial in the denominator of the transfer function. The realization of a second-order low-pass Butterworth filter is made by a circuit with the following transfer function:

$$H_{LP}(f) = \frac{K}{-\left(\frac{f}{f_c}\right)^2 + 1.414 \frac{jf}{f_c} + 1}$$

Equation 2. Second-Order Low-Pass Butterworth Filter

This is the same as Equation 1 with $FSF = 1$ and $Q = \frac{1}{1.414} = 0.707$.

5.2 Second-Order Low-Pass Bessel Filter

Referring to a table listing the zeros of the second-order Bessel polynomial, we find: $z_1 = -1.103 + j0.6368$, $z_1^* = -1.103 - j0.6368$; a table of coefficients provides: $a_0 = 1.622$ and $a_1 = 2.206$.

Again, using the coefficient form lends itself to our standard form, so that the realization of a second-order low-pass Bessel filter is made by a circuit with the transfer function:

$$H_{LP}(f) = \frac{K}{-\left(\frac{f}{f_c}\right)^2 + 2.206 \frac{jf}{f_c} + 1.622}$$

Equation 3. Second-Order Low-Pass Bessel Filter – From Coefficient Table

We need to normalize Equation 3 to correlate with Equation 1. Dividing through by 1.622 is essentially scaling the gain factor K (which is arbitrary) and normalizing the equation:

$$H_{LP}(f) = \frac{K}{-\left(\frac{f}{1.274f_c}\right)^2 + 1.360 \frac{jf}{f_c} + 1}$$

Equation 4. Second-Order Low-Pass Bessel Filter – Normalized Form

Equation 4 is the same as Equation 1 with $FSF = 1.274$ and $Q = \frac{1}{1.360 \times 1.274} = 0.577$.

5.3 Second-Order Low-Pass Chebyshev Filter With 3-dB Ripple

Referring to a table listing for a 3-dB second-order Chebyshev, the zeros are given as $z_1 = -0.3224 + j0.7772$, $z_1^* = -0.3224 - j0.7772$. From a table of coefficients we get: $a_0 = 0.7080$ and $a_1 = 0.6448$.

Again, using the coefficient form lends itself to a circuit implementation, so that the realization of a second-order low-pass Chebyshev filter with 3-dB of ripple is accomplished with a circuit having a transfer function of the form:

$$H_{LP}(f) = \frac{K}{-\left(\frac{f}{f_c}\right)^2 + 0.6448 \frac{jf}{f_c} + 0.7080}$$

Equation 5. Second-Order Low-Pass Chebyshev Filter With 3-dB Ripple – From Coefficient Table

Dividing top and bottom by 0.7080 is again simply scaling of the gain factor K (which is arbitrary), so we normalize the equation to correlate with Equation 1 and get:

$$H_{LP}(f) = \frac{K}{-\left(\frac{f}{0.8414f_c}\right)^2 + 0.9107 \frac{jf}{f_c} + 1}$$

Equation 6. Second-Order Low-Pass Chebyshev Filter With 3-dB Ripple – Normalized Form

Equation 6 is the same as Equation 1 with $FSF = 0.8414$ and $Q = \frac{1}{0.8414 \times 0.9107} = 1.3050$.

The previous work is the first step in designing any of the filters. The next step is to determine a circuit to implement these filters.

6 Low-Pass Sallen-Key Architecture

Figure 1 shows the low-pass Sallen-Key architecture and its ideal transfer function.

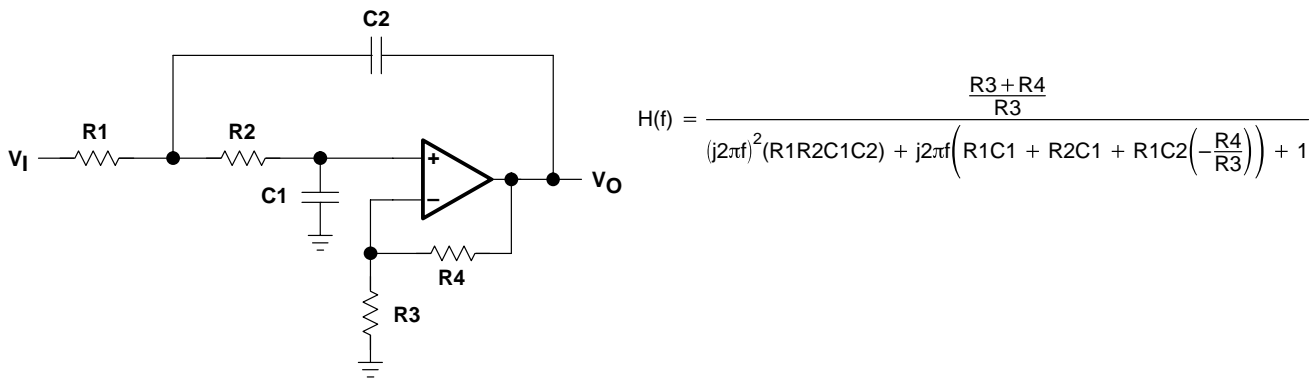

Figure 1. Low-Pass Sallen-Key Architecture

At first glance, the transfer function looks very different from our standard form in Equation 1. Let us make the following substitutions: $K = \frac{R3 + R4}{R3}$, $FSF \times f_c = \frac{1}{2\pi \sqrt{R1R2C1C2}}$, and

$$Q = \frac{\sqrt{R1R2C1C2}}{R1C1 + R2C1 + R1C2(1-K)}, \text{ and they become the same.}$$

Depending on how you use the previous equations, the design process can be simple or tedious. Appendix A shows simplifications that help to ease this process.

7 Low-Pass Multiple-Feedback (MFB) Architecture

Figure 2 shows the MFB filter architecture and its ideal transfer function.

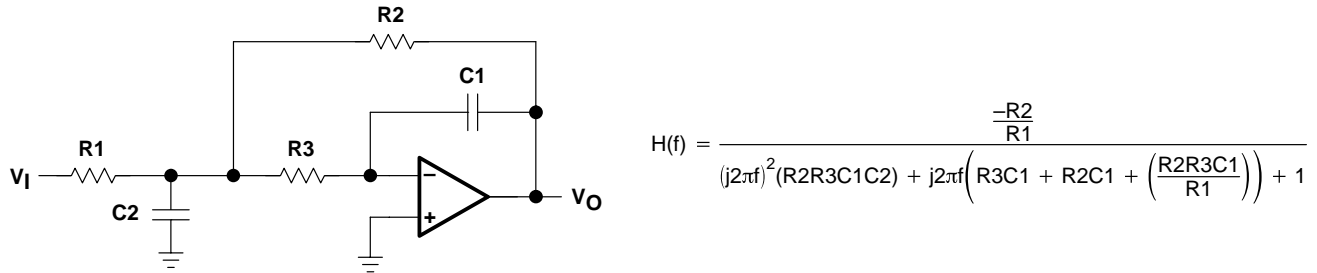

Figure 2. Low-Pass MFB Architecture

Again, the transfer function looks much different than our standard form in Equation 1. Make the following substitutions: $K = \frac{-R2}{R1}$, $FSF \times fc = \frac{1}{2\pi \sqrt{R2R3C1C2}}$, and

$Q = \frac{\sqrt{R2R3C1C2}}{R3C1 + R2C1 + R3C1(-K)}$, and they become the same.

Depending on how you use the previous equations, the design process can be simple or tedious. Appendix A shows simplifications that help to ease this process.

The Sallen-Key and MFB circuits shown are second-order low-pass stages that can be used to realize one complex-pole pair in the transfer function of a low-pass filter. To make a Butterworth, Bessel, or Chebyshev filter, set the value of the corresponding circuit components to equal the coefficients of the filter polynomials. This is demonstrated later.

8 Cascading Filter Stages

The concept of cascading second-order filter stages to realize higher-order filters is illustrated in Figure 3. The filter is broken into complex-conjugate-pole pairs that can be realized by either Sallen-Key, or MFB circuits (or a combination). To implement an n -order filter, $n/2$ stages are required. Figure 4 extends the concept to odd-order filters by adding a first-order real pole. Theoretically, the order of the stages makes no difference, but to help avoid saturation, the stages are normally arranged with the lowest Q near the input and the highest Q near the output. Appendix B shows detailed circuit examples using cascaded stages for higher-order filters.

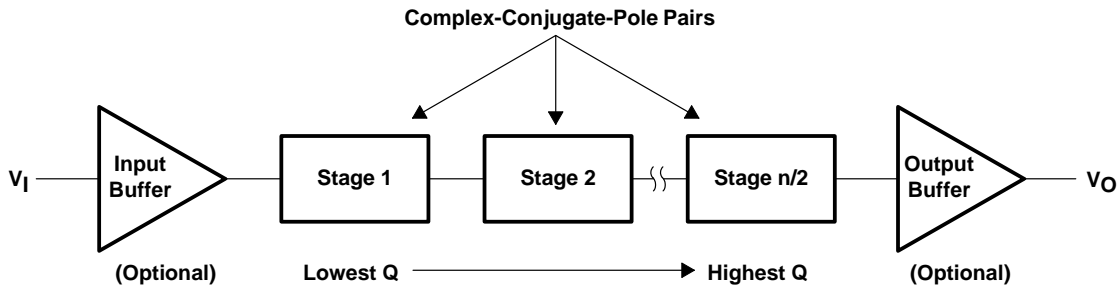

Figure 3. Building Even-Order Filters by Cascading Second-Order Stages

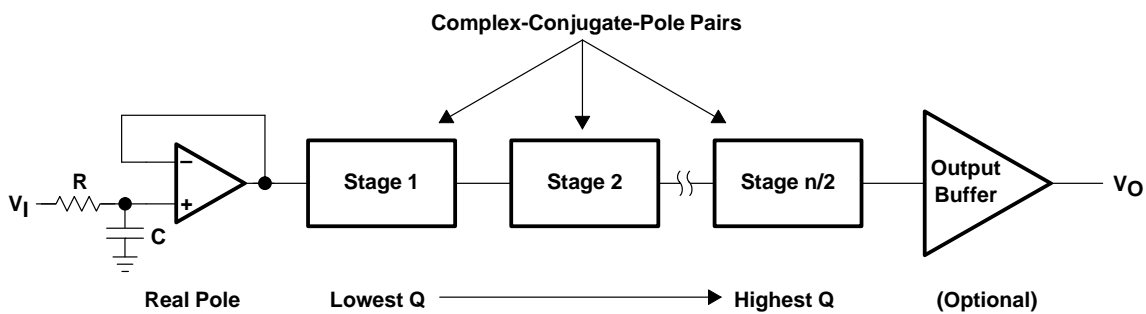

Figure 4. Building Odd-Order Filters by Cascading Second-Order Stages and Adding a Single Real Pole

9 Filter Tables

Typically, filter books list the zeroes or the coefficients of the particular polynomial being used to define the filter type. As we have seen, it takes a certain amount of mathematical manipulation to turn this information into a circuit realization. Although this work is required, it is merely a mechanical operation using the following relationships: frequency scaling factor,

$$FSF = \sqrt{\text{Re}^2 + |\text{Im}|^2}, \text{ and quality factor } Q = \frac{\sqrt{\text{Re}^2 + |\text{Im}|^2}}{2\text{Re}}$$
 where Re is the real part of the complex-zero pair, and Im is the imaginary part. Tables 1 through 4 are generated in this way. It is implicit that higher-order filters are constructed by cascading second-order stages for even-order filters (one for each complex-zero pair). A first-order stage is then added if the filter order is odd. With the filter tables arranged this way, the preliminary mathematical work is done and the designer is left with calculating the proper circuit components based on just three formulas.

For a low-pass Sallen-Key filter with cutoff frequency f_c and pass-band gain K , set

$$K = \frac{R_3 + R_4}{R_3}, \text{FSF} \times f_c = \frac{1}{2\pi \sqrt{R_1 R_2 C_1 C_2}}, \text{ and } Q = \frac{\sqrt{R_1 R_2 C_1 C_2}}{R_1 C_1 + R_2 C_1 + R_1 C_2(1-K)}$$

for each second-order stage. If an odd order is required, set $\text{FSF} \times f_c = \frac{1}{2\pi RC}$ for that stage.

For a low-pass MFB filter with cutoff frequency f_c and pass-band gain K , set

$$K = \frac{-R_2}{R_1}, \text{FSF} \times f_c = \frac{1}{2\pi \sqrt{R_2 R_3 C_1 C_2}}, \text{ and } Q = \frac{\sqrt{R_2 R_3 C_1 C_2}}{R_3 C_1 + R_2 C_1 + R_3 C_1(-K)}$$

for each second-order stage. If an odd order is required, set $\text{FSF} \times f_c = \frac{1}{2\pi RC}$ for that stage.

The tables are arranged so that increasing Q is associated with increasing stage order. High-order filters are normally arranged in this manner to help prevent clipping.

Table 1. Butterworth Filter Table

FILTER ORDER	Stage 1		Stage 2		Stage 3		Stage 4		Stage 5	
	FSF	Q	FSF	Q	FSF	Q	FSF	Q	FSF	Q
2	1.000	0.7071								
3	1.000	1.0000	1.000							
4	1.000	0.5412	1.000	1.3065						
5	1.000	0.6180	1.000	1.6181	1.000					
6	1.000	0.5177	1.000	0.7071	1.000	1.9320				
7	1.000	0.5549	1.000	0.8019	1.000	2.2472	1.000			
8	1.000	0.5098	1.000	0.6013	1.000	0.8999	1.000	2.5628		
9	1.000	0.5321	1.000	0.6527	1.000	1.0000	1.000	2.8802	1.000	
10	1.000	0.5062	1.000	0.5612	1.000	0.7071	1.000	1.1013	1.000	3.1969

Table 2. Bessel Filter Table

FILTER ORDER	Stage 1		Stage 2		Stage 3		Stage 4		Stage 5	
	FSF	Q	FSF	Q	FSF	Q	FSF	Q	FSF	Q
2	1.2736	0.5773								
3	1.4524	0.6910	1.3270							
4	1.4192	0.5219	1.5912	0.8055						
5	1.5611	0.5635	1.7607	0.9165	1.5069					
6	1.6060	0.5103	1.6913	0.6112	1.9071	1.0234				
7	1.7174	0.5324	1.8235	0.6608	2.0507	1.1262	1.6853			
8	1.7837	0.5060	2.1953	1.2258	1.9591	0.7109	1.8376	0.5596		
9	1.8794	0.5197	1.9488	0.5894	2.0815	0.7606	2.3235	1.3220	1.8575	
10	1.9490	0.5040	1.9870	0.5380	2.0680	0.6200	2.2110	0.8100	2.4850	1.4150

Table 3. 1-dB Chebyshev Filter Table

FILTER ORDER	Stage 1		Stage 2		Stage 3		Stage 4		Stage 5	
	FSF	Q	FSF	Q	FSF	Q	FSF	Q	FSF	Q
2	1.0500	0.9565								
3	0.9971	2.0176	0.4942							
4	0.5286	0.7845	0.9932	3.5600						
5	0.6552	1.3988	0.9941	5.5538	0.2895					
6	0.3532	0.7608	0.7468	2.1977	0.9953	8.0012				
7	0.4800	1.2967	0.8084	3.1554	0.9963	10.9010	0.2054			
8	0.2651	0.7530	0.5838	1.9564	0.5538	2.7776	0.9971	14.2445		
9	0.3812	1.1964	0.6623	2.7119	0.8805	5.5239	0.9976	18.0069	0.1593	
10	0.2121	0.7495	0.4760	1.8639	0.7214	3.5609	0.9024	6.9419	0.9981	22.2779

Table 4. 3-dB Chebyshev Filter Table

FILTER ORDER	Stage 1		Stage 2		Stage 3		Stage 4		Stage 5	
	FSF	Q	FSF	Q	FSF	Q	FSF	Q	FSF	Q
2	0.8414	1.3049								
3	0.9160	3.0678	0.2986							
4	0.4426	1.0765	0.9503	5.5770						
5	0.6140	2.1380	0.9675	8.8111	0.1775					
6	0.2980	1.0441	0.7224	3.4597	0.9771	12.7899				
7	0.4519	1.9821	0.7920	5.0193	0.9831	17.4929	0.1265			
8	0.2228	1.0558	0.5665	3.0789	0.8388	6.8302	0.9870	22.8481		
9	0.3559	1.9278	0.6503	4.3179	0.8716	8.8756	0.9897	28.9400	0.0983	
10	0.1796	1.0289	0.4626	2.9350	0.7126	5.7012	0.8954	11.1646	0.9916	35.9274

10 Example-Circuit Test Results

To further show how to use the above information and see actual circuit performance, component values are calculated and the filter circuits are built and tested.

Figures 5 and 6 show typical component values computed for the three different filters discussed using the Sallen-Key architecture and the MFB architecture. The equivalent simplification (see Appendix A) is used for each circuit: setting the filter components as ratios and the gain equal to 1 for the Sallen-Key, and the gain equal to -1 for the MFB. The circuits and simplifications are shown for convenience. A corner frequency of 1 kHz is chosen. The values used for m and n are shown. $C1$ and $C2$ are chosen to be standard values. The values shown for $R1$ and $R2$ are the nearest standard values to those computed by using the formulas given.

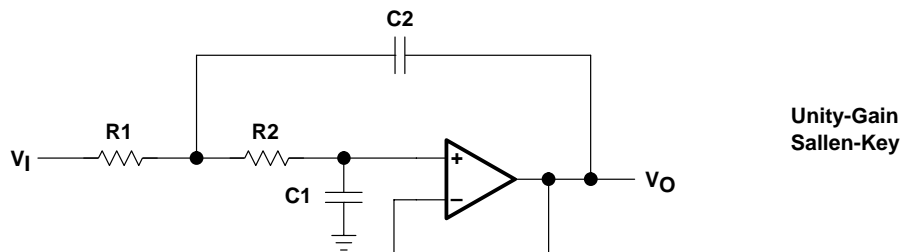

$$R1=mR, R2=R, C1=C, C2=nC, \text{ and } K=1 \text{ result in: } FSF \times fc = \frac{1}{2\pi RC \sqrt{mn}}, \text{ and } Q = \frac{\sqrt{mn}}{m+1}$$

FILTER TYPE	n	m	C1	C2	R1	R2
Butterworth	3.3	0.229	0.01 μ F	0.033 μ F	4.22 k Ω	18.2 k Ω
Bessel	1.5	0.42	0.01 μ F	0.015 μ F	7.15 k Ω	14.3 k Ω
3-dB Chebyshev	6.8	1.0	0.01 μ F	0.068 μ F	7.32 k Ω	7.32 k Ω

Figure 5. Sallen-Key Circuit and Component Values – $fc = 1$ kHz

$$R2=R, R3=mR, C1=C, C2=nC, \text{ and } K=1 \text{ results in: } FSF \times fc = \frac{1}{2\pi RC \sqrt{mn}}, \text{ and } Q = \frac{\sqrt{mn}}{1+2m}$$

FILTER TYPE	n	m	C1	C2	R1 & R2	R3
Butterworth	4.7	0.222	0.01 μ F	0.047 μ F	15.4 k Ω	3.48 k Ω
Bessel	3.3	0.195	0.01 μ F	0.033 μ F	15.4 k Ω	3.01 k Ω
3-dB Chebyshev	15	10.268	0.01 μ F	0.15 μ F	9.53 k Ω	2.55 k Ω

Figure 6. MFB Circuit and Component Values – $fc = 1$ kHz

The circuits are built using a TLV2772 operational amplifier, 1%-tolerance resistors, and 10%-tolerance capacitors. Figures 7 through 10 show the measured frequency response of the circuits. Figure 11 shows the transient response of the filters to a pulse input.

Figure 7 compares the frequency response of Sallen-Key and MFB second-order Butterworth filters. The frequency response of the filters is almost identical from 10 Hz to about 40 kHz. Above this, the MFB shows better performance. This will be examined later.

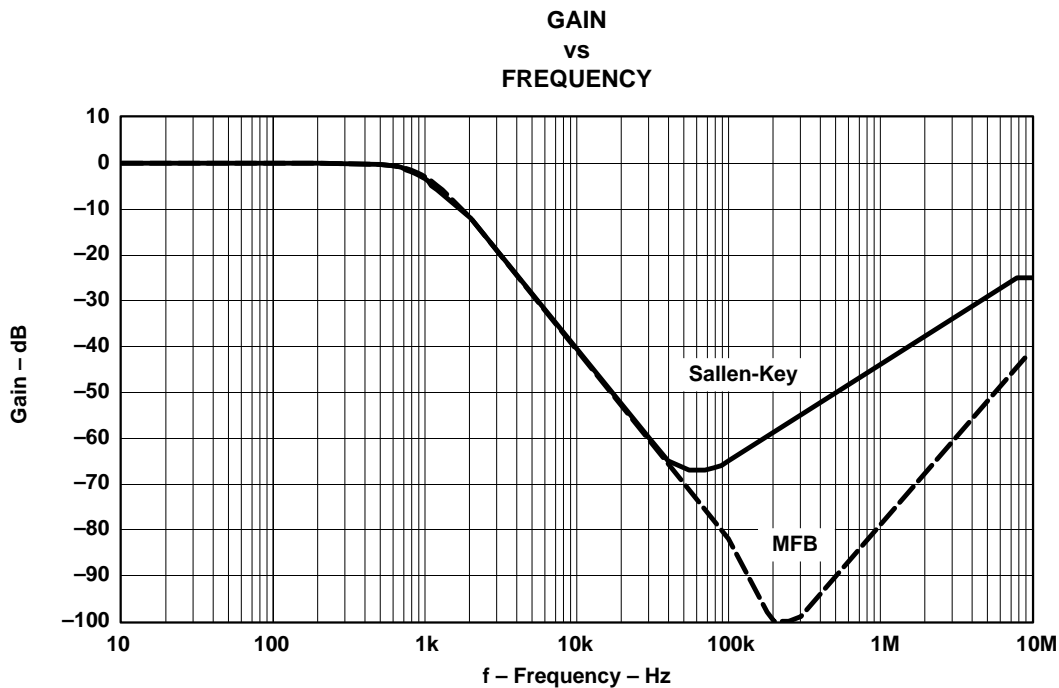

Figure 7. Second-Order Butterworth Filter Frequency Response

Figure 8 compares the frequency response of Sallen-Key and MFB second-order Bessel filters. The frequency response of the filters is almost identical from 10 Hz to about 50 kHz. Above this, the MFB has superior performance. This will be examined later.

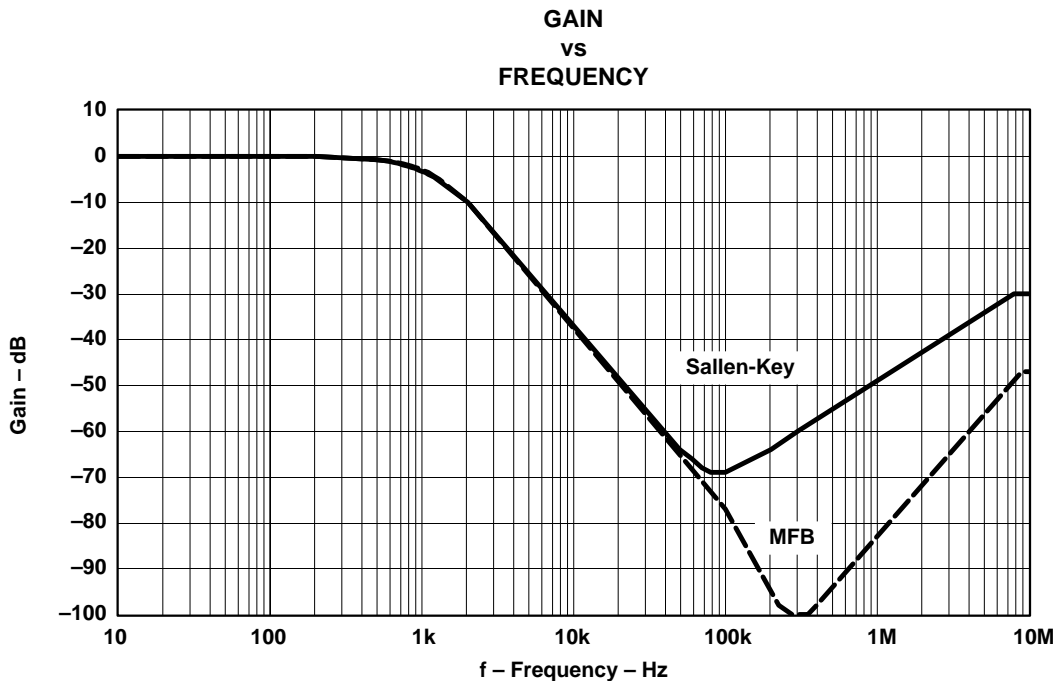

Figure 8. Second-Order Bessel Filter Frequency Response

Figure 9 compares the frequency response of Sallen-Key and MFB second-order 3-dB Chebyshev filters. The frequency response of the filters is almost identical from 10 Hz to about 50 kHz. Above this, the MFB shows better performance. This will be examined shortly.

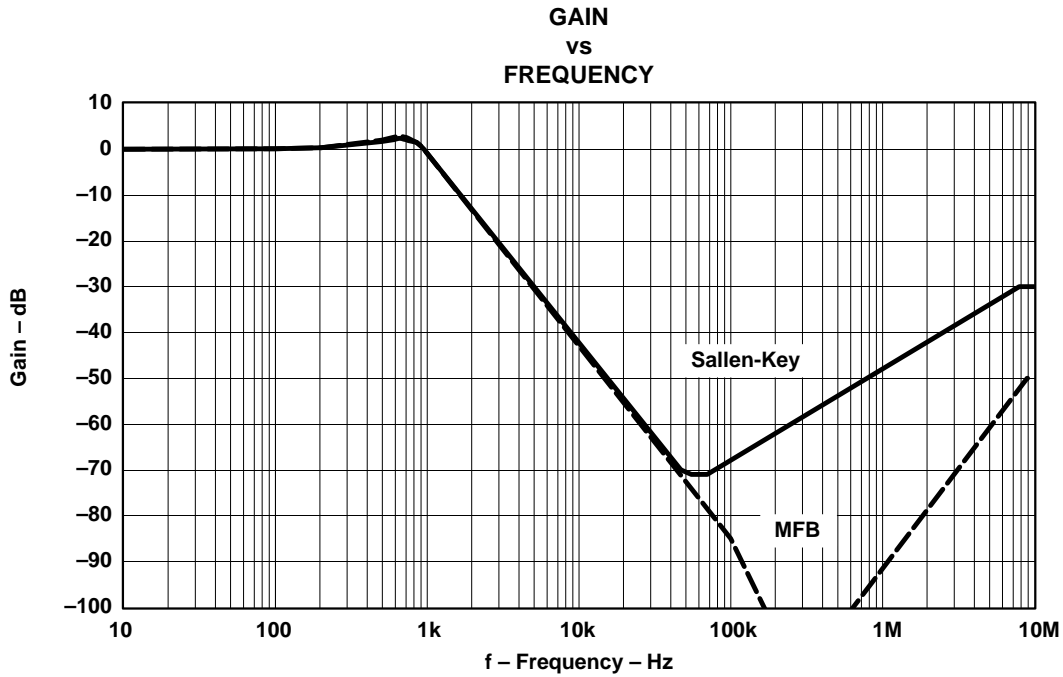

Figure 9. Second-Order 3-dB Chebyshev Filter Frequency Response

Figure 10 is an expanded view of the frequency response of the three filters in the MFB topology, near f_c (the Sallen-Key circuits are almost identical). It clearly shows the increased rate of attenuation near the cutoff frequency, going from the Bessel to the 3-dB Chebyshev.

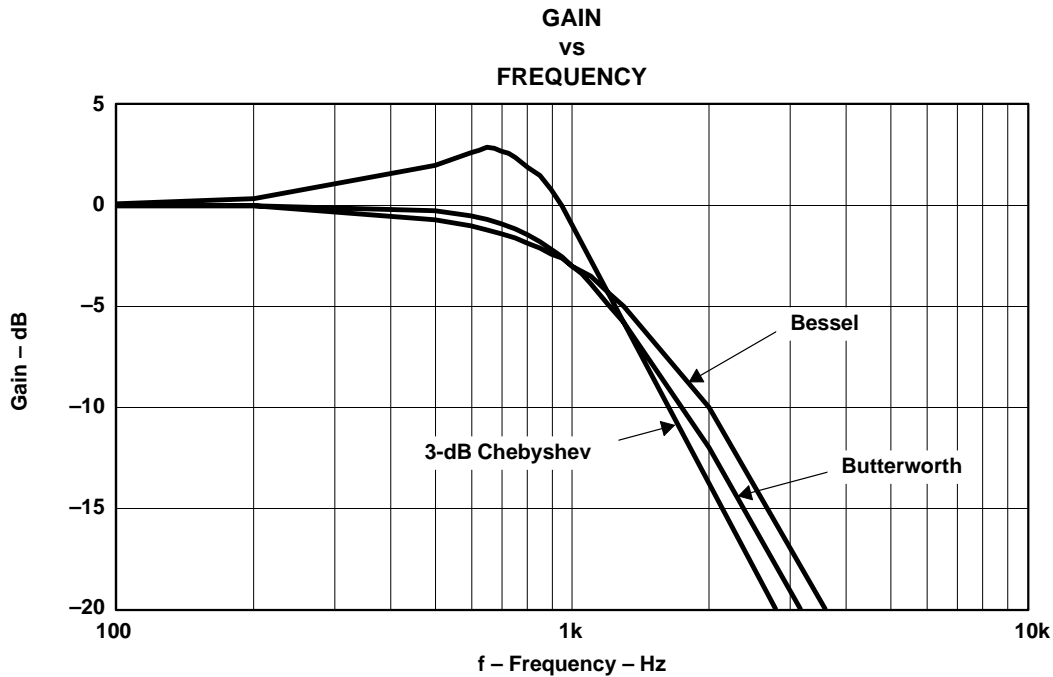

Figure 10. Second-Order Butterworth, Bessel, and 3-dB Chebyshev Filter Frequency Response

Figure 11 shows the transient response of the three filters using MFB architecture to a pulse input (the Sallen-Key circuits are almost identical). It clearly shows the increased overshoot going from the Bessel to the 3-dB Chebyshev.

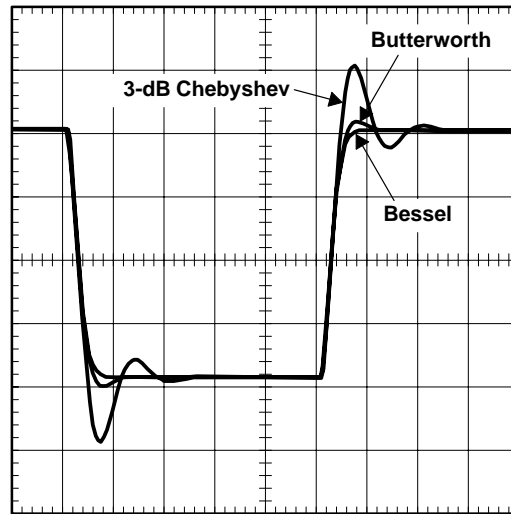

Figure 11. Transient Response of the Three Filters

11 Nonideal Circuit Operation

Up to now we have not discussed nonideal operation of the circuits. The test results shown in Figures 7 through 9 show that at high frequency, where you expect the response to keep attenuating at -40 dB/dec, the filters actually turn around and start passing signals at increasing amplitudes. We will now examine why this happens.

11.1 Nonideal Circuit Operation – Sallen-Key

At frequencies well above cutoff, simplified high-frequency models help show the expected behavior of the circuits. Figure 12 is used to show the expected circuit operation for a second-order low-pass Sallen-Key circuit at high frequency. The assumption made here is that C1 and C2 are effective shorts when compared to the impedance of R1 and R2 so that the amplifier's input is at ac ground. In response, the amplifier generates an ac ground at its output, limited only by its output impedance Z_o . The formula shows the transfer function of this model.

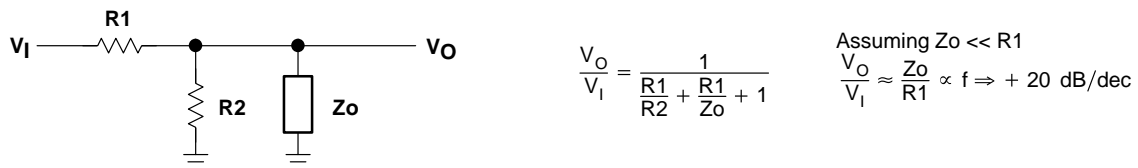

Figure 12. Second-Order Low-Pass Sallen-Key High-Frequency Model

Z_o is the closed-loop output impedance. It depends on the loop transmission and the open-loop output impedance z_o : $Z_o = \frac{z_o}{1 + a(f)\beta}$, where $a(f)\beta$ is the loop transmission. β is the feedback factor set by resistors R3 and R4 and is constant over frequency, but the open loop gain $a(f)$ is dependant on frequency. With dominant-pole compensation, the open-loop gain of the amplifier decreases at -20 dB/dec over the usable frequencies of operation. Assuming that z_o is mainly resistive (usually a valid assumption up to 100 MHz), Z_o increases at a rate of 20 dB/dec. At high frequencies the circuit is no longer able to attenuate the input and begins to pass the signal at a 20-dB/dec rate, as the test results show.

Placing a low-pass RC filter at the output of the amplifier can help nullify the feed-through of high-frequency signals. Figure 13 shows a comparison between the original Sallen-Key Butterworth filter and one using an RC filter on the output. A 100- Ω resistor is placed in series with the output, and a 0.047- μ F capacitor is connected from the output to ground. This places a passive pole in the transfer function at about 40 kHz that improves the high-frequency response.

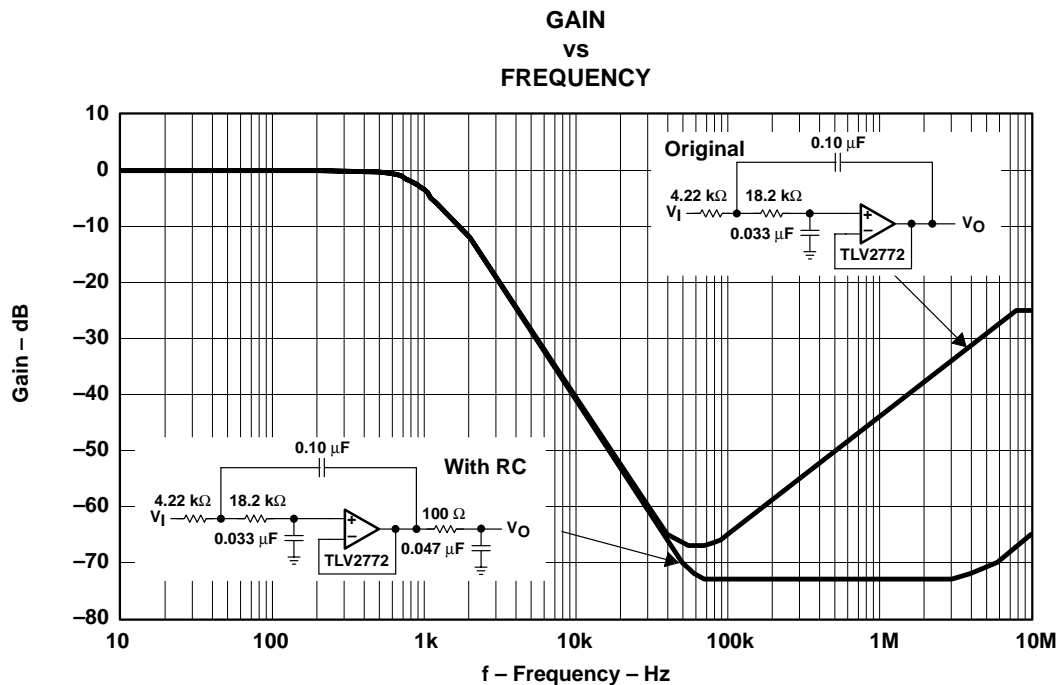

Figure 13. Sallen-Key Butterworth Filter With RC Added in Series With the Output

11.2 Nonideal Circuit Operation – MFB

The high-frequency analysis of the MFB is very similar to the Sallen-Key. Figure 14 is used to show the expected circuit operation for a second-order low-pass MFB circuit at high frequency. The assumption made here is that C1 and C2 are effective shorts when compared to the impedance of R1, R2, and R3. Again, the amplifier's input is at ac ground, and generates an ac ground at its output limited only by its output impedance Z_o . Capacitor C_p represents the parasitic capacitance from V_I to V_O . The ability of the circuit to attenuate high-frequency signals is dependent on C_p and Z_o . The impedance of C_p decreases at -20 dB/dec and Z_o increases at 20 dB/dec. The overall transfer function turns around at high frequency to 40 dB/dec as seen in the laboratory data. Spice simulation shows that as little as 0.4 pF will produce the high-frequency feed through observed.

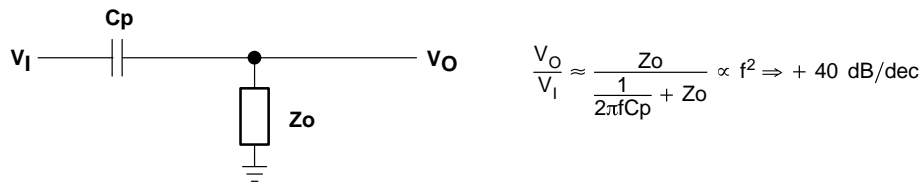

Figure 14. Second-Order Low-Pass MFB High-Frequency Model

Care should be taken when routing the input and output signals to keep capacitive coupling to a minimum.

Placing a low-pass RC filter at the output of the amplifier can help nullify the feed through of high-frequency signals. Figure 15 below shows a comparison between the original MFB Butterworth filter with one using an RC filter on the output. A $100\text{-}\Omega$ resistor is placed in series with the output, and a $0.047\text{-}\mu\text{F}$ capacitor is connected from the output to ground. This places a passive pole in the transfer function at about 40 kHz that improves the high-frequency response.

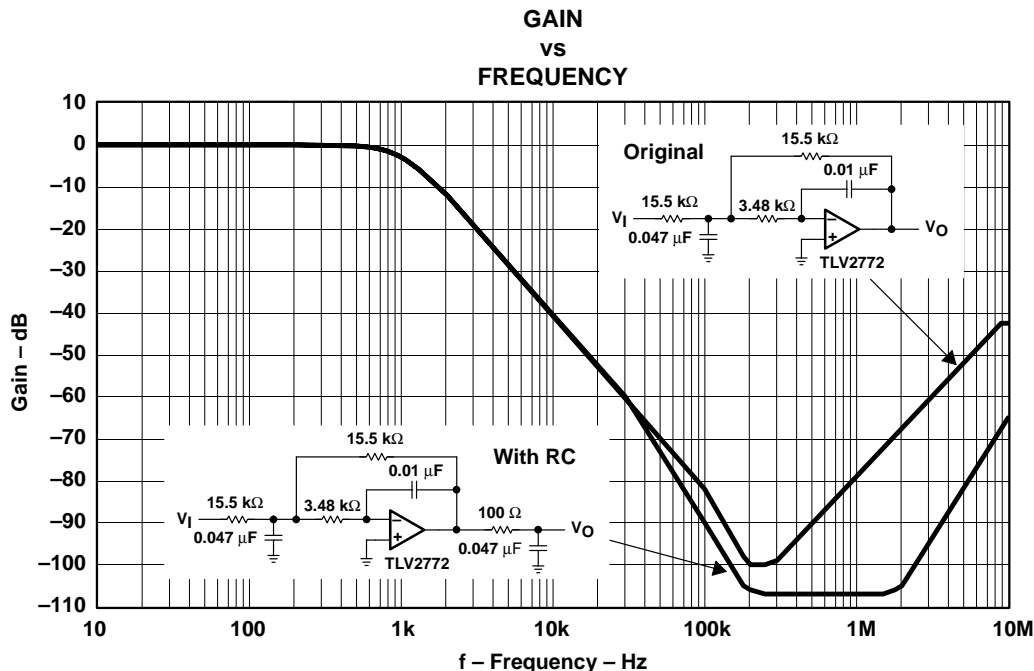

Figure 15. MFB Butterworth Filter With RC Added in Series With the Output

12 Comments About Component Selection

Theoretically, any values of R and C which satisfy the equations might be used, but practical considerations call for certain guidelines to be followed.

Given a specific corner frequency, the values of R and C are inversely proportional to each other. By making C larger R becomes smaller, and vice versa.

Making R large may make C so small that parasitic capacitors cause errors. This makes smaller resistor values preferred over larger resistor values.

The best choice of component values depends on the particulars of your circuit and the tradeoffs you are willing to make. Adhering to the following general recommendations will help reduce errors:

- **Capacitors**

- Avoid values less than 10 pF
- Use NPO or COG dielectrics
- Use 1%-tolerance components
- Surface mount is preferred.

- **Resistors**

- Values in the range of a few-hundred ohms to a few-thousand ohms are best.
- Use metal film with low-temperature coefficients.
- Use 1% tolerance (or better).
- Surface mount is preferred.

13 Conclusion

We have investigated building second-order low-pass Butterworth, Bessel, and 3-dB Chebyshev filters using the Sallen-Key and MFB architectures. The same techniques are extended to higher-order filters by cascading second-order stages for even order, and adding a first-order stage for odd order.

The advantages of each filter type come at the expense of other characteristics. The Butterworth is considered by a lot of people to offer the best all-around filter response. It has maximum flatness in the pass-band with moderate rolloff past cutoff, and shows only slight overshoot in response to a pulse input.

The Bessel is important when signal-conditioning square-wave signals. The constant-group delay means that the square-wave signal is passed with minimum distortion (overshoot). This comes at the expense of a slower rate of attenuation above cutoff.

The 3-dB Chebyshev sacrifices pass-band flatness for a high rate of attenuation near cutoff. It also exhibits the largest overshoot and ringing in response to a pulse input of the three filter types discussed.

The Sallen-Key and MFB architectures also have trade-offs associated with them. The simplifications that can be used when designing the Sallen-Key provide for easier selection of circuit components, and at unity gain, it has no gain sensitivity to component variations. The MFB shows less overall sensitivity to component variations and has superior high-frequency performance.

Tables 5 and 6 give a brief summary of the previous trade-offs.

Table 5. Summary of Filter Type Trade-Offs

FILTER TYPE	ADVANTAGE(s)	DISADVANTAGE(s)
Butterworth	Maximum pass-band flatness	Slight overshoot in response to pulse input and moderate rate of attenuation above f_c
Bessel	Constant group delay – no overshoot with pulse input	Slow rate of attenuation above f_c
3-dB Chebyshev	Fast rate of attenuation above f_c	Large overshoot and ringing in response to pulse input

Table 6. Summary of Architecture Trade-Offs

ARCHITECTURE	ADVANTAGE(s)	DISADVANTAGE(s)
Sallen-Key	Not sensitive to component variation at unity gain	High-frequency response limited by the frequency response of the amplifier
MFB	Less sensitive to component variations and superior high-frequency response	Less simplifications available to ease design

Appendix A Filter-Design Specifications

A.1 Sallen-Key Design Simplifications

Depending upon how you go about working the equations which describe the Sallen-Key transfer function, filter design can be simple or tedious. The following simplifications can be used to ease design, but note that the easier the design becomes, the more it limits the design freedom.

A.1.1 S-K Simplification 1: Set Filter Components as Ratios

Letting $R_1=mR$, $R_2=R$, $C_1=C$, and $C_2=nC$, results in: $FSF \times f_c = \frac{1}{2\pi RC \sqrt{mn}}$ and

$Q = \frac{\sqrt{mn}}{m + 1 + mn(1-K)}$. This is the most rudimentary of simplifications. Design should start by determining the ratios m and n required for the gain and Q of the filter, and then selecting C and calculating R to set f_c .

A.1.2 S-K Simplification 2: Set Filter Components as Ratios and Gain = 1

Letting $R_1=mR$, $R_2=R$, $C_1=C$, $C_2=nC$, and $K=1$ results in: $FSF \times f_c = \frac{1}{2\pi RC \sqrt{mn}}$ and

$Q = \frac{\sqrt{mn}}{m + 1}$. This sets the gain = 0 dB in the pass band. Design should start by determining the ratios m and n for the required Q of the filter, and then selecting C and calculating R to set f_c .

A.1.3 S-K Simplification 3: Set Resistors as Ratios and Capacitors Equal

Letting $R_1=mR$, $R_2=R$, and $C_1=C_2=C$, results in: $FSF \times f_c = \frac{1}{2\pi RC \sqrt{m}}$ and $Q = \frac{\sqrt{m}}{1 + m(2-K)}$.

The main motivation behind setting the capacitors equal is the limited selection of values in comparison to resistors.

There is interaction between setting f_c and Q . Design should start with choosing m and K to set the gain and Q of the circuit, and then choosing C and calculating R to set f_c .

A.1.4 S-K Simplification 4: Set Filter Components Equal

Letting $R_1=R_2=R$ and $C_1=C_2=C$ results in: $FSF \times f_c = \frac{1}{2\pi RC}$ and $Q = \frac{1}{3-K}$. With this simplification, f_c and Q are independent of each other. Q is now determined by the gain of the circuit. f_c is set by choice of RC —the capacitor should be chosen and the resistor calculated. Since the gain controls the Q of the circuit, further gain or attenuation may be necessary to achieve the desired signal level in the pass band.

A.2 MFB Design Simplifications

The MFB does not have as many simplifications that make sense as the Sallen-Key, but the following simplification may be useful.

A.2.1 MFB Simplification 1: Set Filter Components as Ratios

Letting $R_2=R$, $R_3=mR$, $C_1=C$, and $C_2=nC$, results in: $FSF \times f_c = \frac{1}{2\pi RC \sqrt{mn}}$ and

$Q = \frac{\sqrt{mn}}{1 + m(1-K)}$. This is the most rudimentary of simplifications. Design should start by determining the ratios m and n required for the gain and Q of the filter, and then selecting C and calculating R to set f_c .

A.2.2 MFB Simplification 2: Set Filter Components as Ratios and Gain = -1

Letting $R_2=R$, $R_3=mR$, $C_1=C$, $C_2=nC$ and $K=-1$ results in: $FSF \times f_c = \frac{1}{2\pi RC \sqrt{mn}}$ and

$Q = \frac{\sqrt{mn}}{1 + 2m}$. This sets the gain = 0 dB in the pass band. Design should start by determining the ratios m and n for the required Q of the filter, and then selecting C and calculating R to set f_c .

Appendix B Higher-Order Filters

B.1 Higher Order Filters

It was stated earlier that higher order filters can be constructed by cascading second-order stages for even-order, and adding a first-order stage for odd-order. To show how this is accomplished we will consider two examples: constructing a fifth-order Butterworth filter, and then a sixth-order Bessel filter.

By breaking higher than second-order filters into complex-conjugate-zero pairs, second-order stages are constructed that, when cascaded, realize the overall polynomial. For example, a sixth-order filter will have three complex-zero pairs and can be written as:

$P_{6th}(s) = (s^2 + z_1)(s + z_1^*)(s + z_2)(s + z_2^*)(s + z_3)(s + z_3^*)$. Each of the complex-conjugate-zero pairs can be multiplied out and written as:

$$(s + z_1)(s + z_1^*) = s^2 + a_{11}s + a_{01}$$

$$(s + z_2)(s + z_2^*) = s^2 + a_{12}s + a_{02}$$

$$(s + z_3)(s + z_3^*) = s^2 + a_{13}s + a_{03}$$

The overall polynomial is then reconstructed in the following form:

$$P_{6th}(s) = (s^2 + a_{11}s + a_{01})(s^2 + a_{12}s + a_{02})(s^2 + a_{13}s + a_{03})$$

The circuit implementation consists of three second-order stages cascaded to form the overall response.

B.1.1 Fifth-Order Low-Pass Butterworth Filter

Referring to Table 1, for a fifth-order Butterworth filter we can write the required circuit transfer function as:

$$H_{LP}(f) = \frac{K}{\left(\frac{jf}{f_c} + 1\right) \left(-\left(\frac{f}{f_c}\right)^2 + \frac{1}{0.6180} \frac{jf}{f_c} + 1\right) \left(-\left(\frac{f}{f_c}\right)^2 + \frac{1}{0.6180} \frac{jf}{f_c} + 1\right)}$$

Figure B–1 shows a Sallen-Key circuit implementation and the required component values. f_c is the -3 -dB point. The overall gain of the circuit in the pass band is $K = K_a \times K_b$.

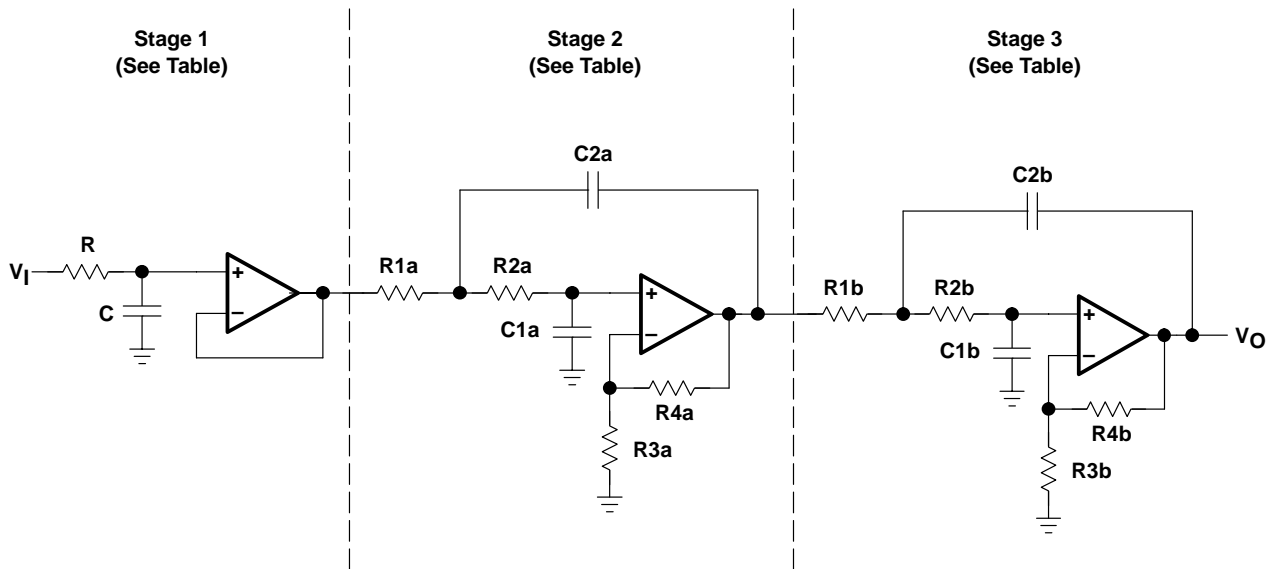

STAGE	f_c	Q	K
1	$\frac{1}{2\pi RC}$	NA	1
2	$\frac{1}{2\pi \sqrt{R1aR2aC1aC2a}}$	$\frac{\sqrt{R1aR2aC1aC2a}}{R1aC1a + R2aC1a + R1aC2a(1-Ka)} = 0.618$	$Ka = \frac{R3a + R4a}{R3a}$
3	$\frac{1}{2\pi \sqrt{R1bR2bC1bC2b}}$	$\frac{\sqrt{R1bR2bC1bC2b}}{R1bC1b + R2bC1b + R1bC2b(1-Kb)} = 1.618$	$Kb = \frac{R3b + R4b}{R3b}$

Figure B–1. Fifth-Order Low-Pass Filter Topology Cascading Two Sallen-Key Stages and an RC

B.1.2 Sixth-Order Low-Pass Bessel Filter

Referring to Table 2 for a sixth-order Bessel filter, we can write the required circuit transfer function as:

$$H_{LP}(f) = \frac{K}{\left(-\left(\frac{f}{1.6060f_c}\right)^2 + 1.2202 \frac{jf}{f_c} + 1\right) \left(-\left(\frac{f}{1.6913f_c}\right)^2 + 0.9674 \frac{jf}{f_c} + 1\right) \left(-\left(\frac{f}{1.9071f_c}\right)^2 + 0.5124 \frac{jf}{f_c} + 1\right)}$$

Figure B–2 shows a MFB circuit implementation and the required component values. f_c is the –3-dB point. The overall gain of the circuit in the pass band is $K = K_a \times K_b \times K_c$.

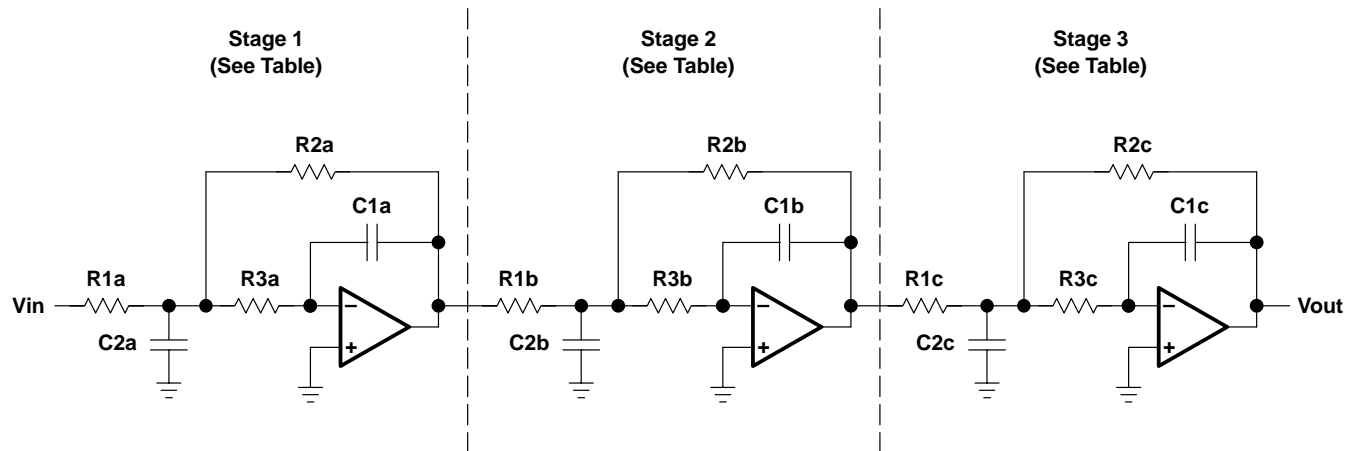

STAGE	f_c	Q	K
1	$\frac{1}{1.6060 \times 2\pi \sqrt{R2aR3aC1aC2a}}$	$\frac{\sqrt{R2aR3aC1aC2a}}{R3aC1a + R2aC1a + R3aC1a(-K_a)} = 0.5103$	$K_a = \frac{-R2a}{R1a}$
2	$\frac{1}{1.6913 \times 2\pi \sqrt{R2bR3bC1bC2b}}$	$\frac{\sqrt{R2bR3bC1bC2b}}{R3bC1b + R2bC1b + R3bC1b(-K_b)} = 0.6112$	$K_b = \frac{-R2b}{R1b}$
3	$\frac{1}{1.9071 \times 2\pi \sqrt{R2cR3cC1cC2c}}$	$\frac{\sqrt{R2cR3cC1cC2c}}{R3cC1c + R2cC1c + R3cC1c(-K_c)} = 1.0234$	$K_c = \frac{-R2c}{R1c}$

Figure B–2. Sixth-Order Low-Pass Filter Topology Cascading Three MFB Stages

IMPORTANT NOTICE

Texas Instruments Incorporated and its subsidiaries (TI) reserve the right to make corrections, modifications, enhancements, improvements, and other changes to its products and services at any time and to discontinue any product or service without notice. Customers should obtain the latest relevant information before placing orders and should verify that such information is current and complete. All products are sold subject to TI's terms and conditions of sale supplied at the time of order acknowledgment.

TI warrants performance of its hardware products to the specifications applicable at the time of sale in accordance with TI's standard warranty. Testing and other quality control techniques are used to the extent TI deems necessary to support this warranty. Except where mandated by government requirements, testing of all parameters of each product is not necessarily performed.

TI assumes no liability for applications assistance or customer product design. Customers are responsible for their products and applications using TI components. To minimize the risks associated with customer products and applications, customers should provide adequate design and operating safeguards.

TI does not warrant or represent that any license, either express or implied, is granted under any TI patent right, copyright, mask work right, or other TI intellectual property right relating to any combination, machine, or process in which TI products or services are used. Information published by TI regarding third-party products or services does not constitute a license from TI to use such products or services or a warranty or endorsement thereof. Use of such information may require a license from a third party under the patents or other intellectual property of the third party, or a license from TI under the patents or other intellectual property of TI.

Reproduction of information in TI data books or data sheets is permissible only if reproduction is without alteration and is accompanied by all associated warranties, conditions, limitations, and notices. Reproduction of this information with alteration is an unfair and deceptive business practice. TI is not responsible or liable for such altered documentation.

Resale of TI products or services with statements different from or beyond the parameters stated by TI for that product or service voids all express and any implied warranties for the associated TI product or service and is an unfair and deceptive business practice. TI is not responsible or liable for any such statements.

Mailing Address:

Texas Instruments
Post Office Box 655303
Dallas, Texas 75265